



TP 3020

- Mobile extraction arm
- With fan VT
- Fan wheel is made self-cleaning for minimal maintenance
- Trolley with 4 wheels, where 2 are turnable and fitted with brakes
- Arm type RGF available in length of 3m
- Arm can turn freely 360°
- With combined hose bracket/handle
- Low centre of gravity
- Suitable for changing workplaces (outlet to outside)



Quick coupling

Can be fitted with quick coupling for extension hose.



Hood

Hood is as standard fitted with damper. Automatic action switch and spotlight are available.



Combination handle

Handle can also be used as hose bracket.



Counterweight

Delivered with counterweight.

The arm is designed with outer bar system. This reduces wear, increases air flow and makes service and adjustment easier.



Additional equipment

Is available with hand-operated motor protection mounted in fitting incl. 5m cable with CE-plug 16A.

Colour: RAL 5007/7011/colour code 9965 silver (structure)

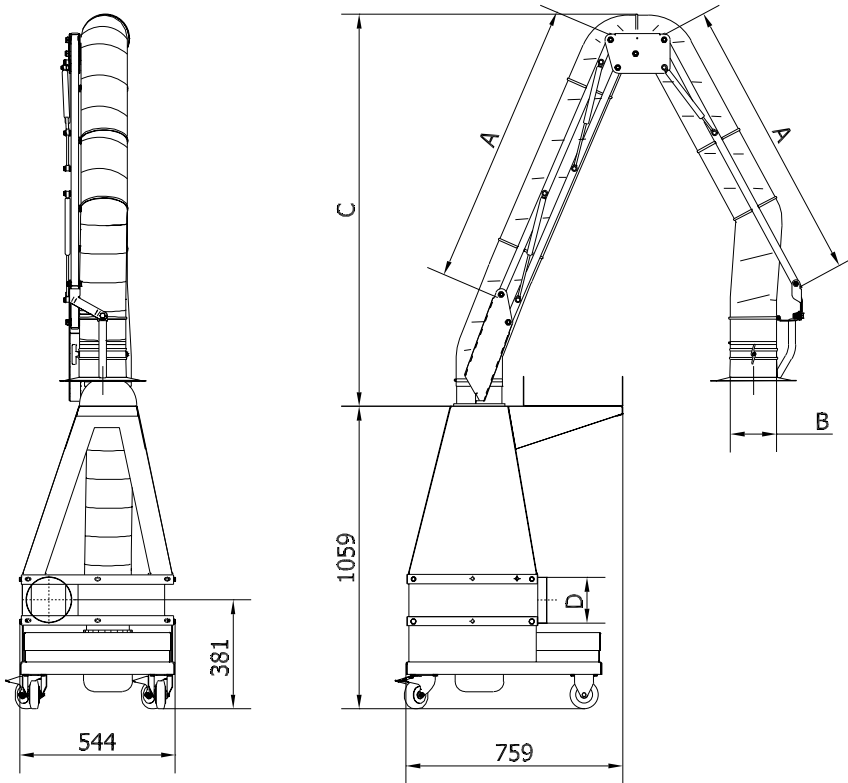

Type	Order no.	Arm	Fan	[kW]	[ϕ]	A	B	C	D	Max. outlet hose length [m]	Noise [db(A)]
TP 3020	01 606 600	RGF 3000	VT 2000	1.10	160	1000	$\phi 161$	1372	$\phi 160$	10	76

Range TP 3020 ($\phi 160$ mm):

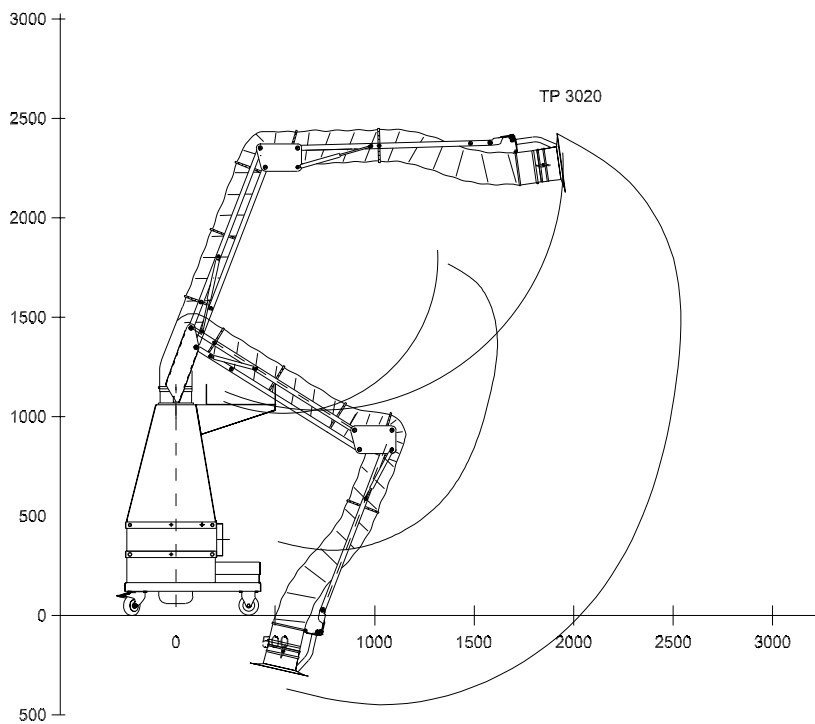

Arm can turn freely 360° in console.

Rev. 03.21 Data is subject to alterations