



Energy-optimized unit for larger filtration tasks, where there is a dust explosion risk, e.g. at filtration of aluminium dust, wood dust or dust from various powder mix handlings. Unit is constructed for application at ATEX-zones 20-22 and is standard equipped with relief membrane, designed to break at an explosion, whereby the unit is relieved and explosions controlled.

Variants	1	2
Inlet and raw air chamber:	Zone 20	Zone 20
Clean air chamber and outlet:	Zone 22	Zone 21
Surroundings:	Zone 22	Zone 21

Unit is standard dimensioned for KST 300bar m/sec. and Pmax 10bar (similar to ST2).

ACF-A / ACF-T-A / ACF-A-HO / ACF-T-A-HO: Air volume: Up to 40,000m³/h
 Vacuum: Up to 5,000Pa
 Filter area: 39 - 468m²

ACF-V-A / ACF-T-V-A: Air volume: Up to 20,000m³/h
 Vacuum: Up to 40,000Pa
 Filter area: 39 - 468m²

Description

- Polluted air is led into unit through tangential inlet in raw air chamber top. Hereby downflow and pre-separation by cyclone effect are ensured, which contributes to load reduction on the filter media itself.
- Air is filtered through vertical-placed filter cartridge with internal filter core, which optimizes cleaning effect.
- Differential pressure-controlled cleaning of filter cartridges through integrated compressed-air system incl. automatic after-cleaning for optimized filter cartridge regeneration.
- Clean air is led out through connection in the side (ACF-A / -V-A / -A-HO)/top (ACF-T-A / -T-V-A) of unit.
- Dust is collected in dust container in unit bottom. Quicklock-adjustable dust container system suspended in ø400mm system flange.
- Explosion membrane is placed at inlet, where it is subject to minimum wear..

Lower operation costs

Inlet with downflow, pre-separation by cyclone effect as well as optimized filter cleaning ensure lower differential pressure above the filter cartridge. Hereby longer operating times with fewer shutdowns as well as lower operation costs (filter materials, power and compressed-air consumption) are obtained.

Simple mounting, connection and operation

Filter unit is delivered fully assembled, is raised and connected. Compressed-air connection made easy on unit front. Easily accessible differential pressure reading in digital display of filter control placed countersunk on unit front. Filters are easily replaced through front doors on unit side. Quicklock-adjustable dust container on 4 turnable wheels ensures user-friendly dust container service.



Service
 Compressed-air tank and all automatic control are countersunk in top/front of unit.



Dust container
 Cone bottom is finished with ø400mm system flange. Standard 72L/67L dust container (excl. sack holder) with 4 turnable wheels.



Easy filter replacement with limited dust generation
 Cartridge replacement is performed by bayonet suspension, which is loosened from clean air chamber and inserted into sack.



Relief membrane
 Relief membrane is placed on the back. Be aware of pressure wave and flame spread through it at relief of a possible dust explosion.

- Filters:**
- Filter cartridge \varnothing 325mm. Length: 660/1320mm
- Filter control:**
- Differential pressure control type ECO-S with automatic after-cleaning. 230V AC (constant)
 - Compressed-air: 5.5 - 6.0 bar dry compressed-air by cejn-coupling incl. \varnothing 10mm hose nipple
 - Differential pressure can be seen in digital display on front
 - 1"-jet valves integrated in pressure tank above filter
- Filter change:** Cartridge replacement made easily and dust-reduced by filter bayonet suspension that is loosened from clean air chamber and inserted into sack. Access by front door.

Filtermaterial:

Standard	Material	Anvendes til
G113	Polyesterflis med PFPT-coating, antistatisk	Statisk ladede eller hygroskopiske partikler

Alternativ

G116A	Polyesterflis med teflon-membran, antistatisk	Finere statisk ladede støvarter
-------	---	---------------------------------

The filters meet demands for extraction degree for dust class M according to DIN EN 60335-2-69 Appendix AA (extraction degree > 99.9%).

**Relief membrane incl. mating flange:****Material:**

Membrane: AISI 304
Mating flange: Galvanized

**Relief pressure: +0.2bar**

Relief area is calculated for the individual unit for $K_{st} = 300\text{bar m/sec}$ and $P_{max} = 10\text{bar}$

Relief membrane is designed as a single unit, which provides a light construction and thus fast opening. The membrane is especially developed for dust explosion relief and gives a reliable ensurance, since it relieves at an early stage, already in the start of an explosion.

NOTE

At installation of units with relief membrane you must be aware of the heavy pressure wave and the flame spread that will occur in areas outside of the relief membrane and mount the unit so that the explosion is led away from people and building components.

Principle sketch for flow through cyclone filter type ACF-A / -V-A / -A-HO:

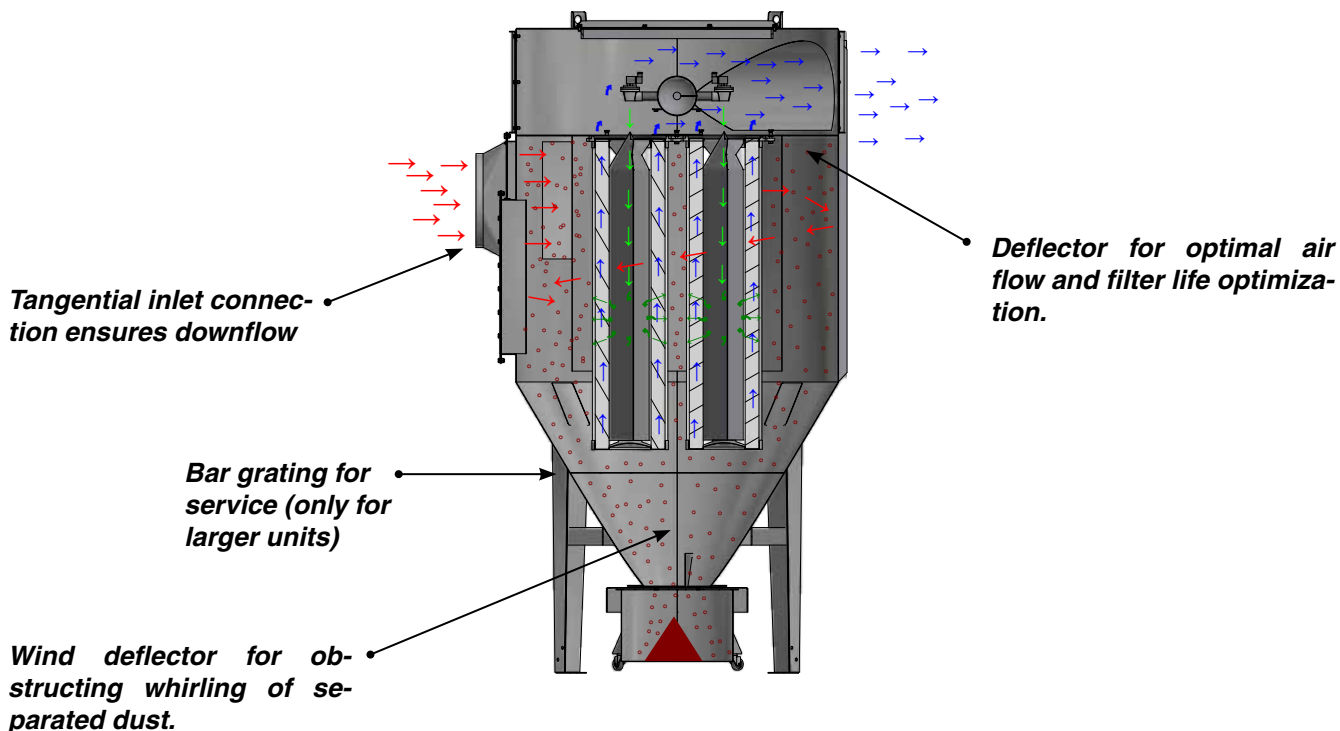

Principle sketch for flow through cyclone filter type ACF-T-A / -T-V-A / -T-A-HO:

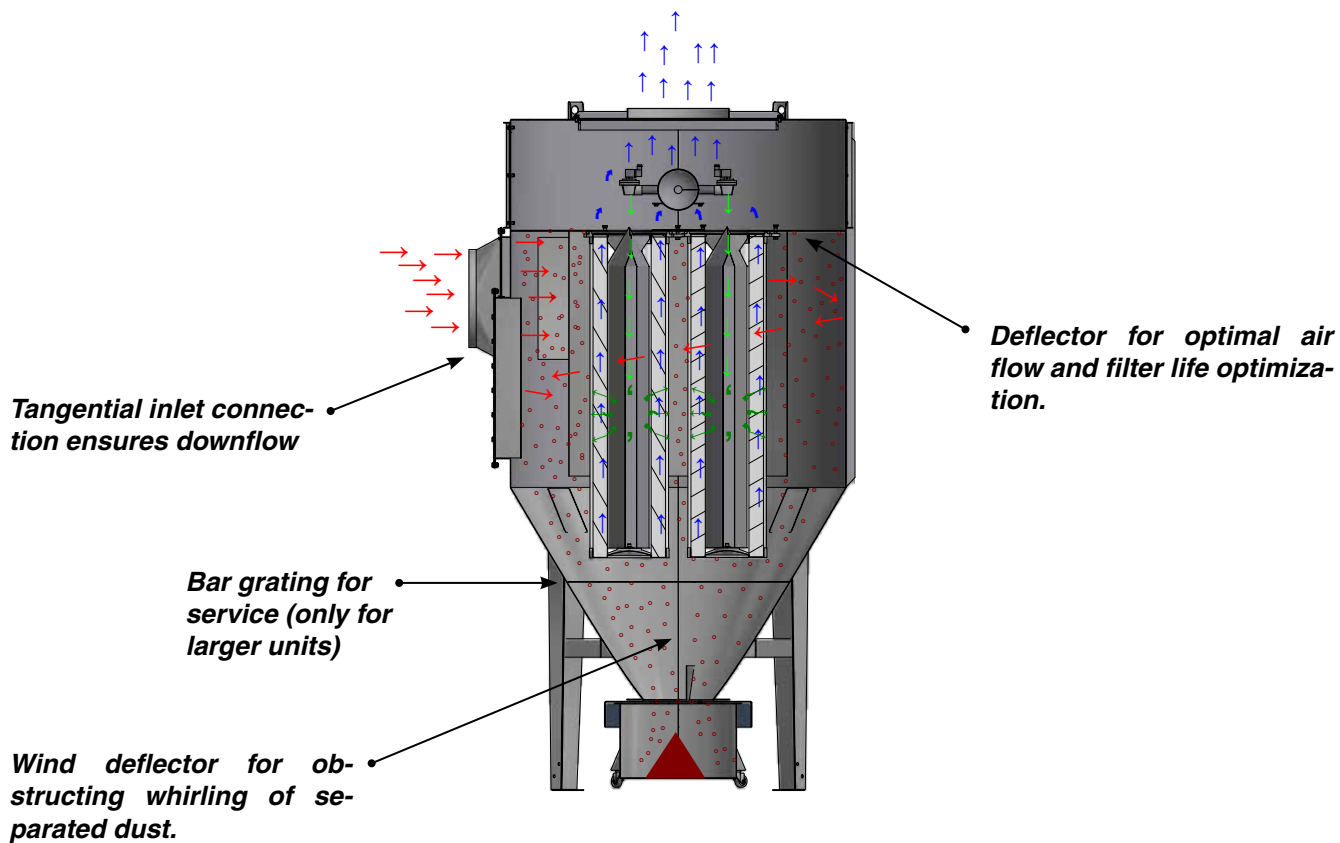

Construction/surface:

Cyclone filter type ACF-A / -T-A / -V-A / -T-V-A / -A-HO / -T-A-HO is constructed according to:

- Machine directive 2006/42/EC
- ATEX directive 2014/34/EU
- EMC directive 2014/30/EU
- Pressure Equipment directive 2014/68/EU
- Low Voltage Directive 2014/35/EU
- Harmonized standards: EN 349, EN 4414, EN 12100, EN 60204-1, EN ISO 13857
- Further standards: ISO 3746

Filter cabinet is made in 2mm black steel plate, fully-welded filter cabinet
Surface powder enamelled RAL 5007/7011 structure

Further is available:

- Version in hot-galvanized, enamelled steel plates for outdoor mounting
- Mirrored connections on inlet/outlet
- Outlet in top lid (for ACF-T-A / -T-V-A / -T-A-HO)
- Gram fans for ACF-T-A or top for building-on other fan (no Gram product)
- Sack holder for 72L/67 dust container
- 150L/145L dust container with sack holder*
- ATEX rotary valve chamber
- ATEX-approved material outlet for bulkbag or tipping container
- ½"-water separator with manometer and pressure reducing valve
- Closed bulkbag cabinet for bulkbag or sliding damper, incl. explosion relief and suspension for bulkbag inside in cabinet for handling with fork lift.
- Rupture sensor for explosion membrane
- Hoerbiger explosion relief valve for type HO

* Note: Unit height is increased by 330mm



Principle sketch for accessories for cyclone filter type ACF-A / -T-A / -V-A / -T-V-A / -A-HO / -T-A-HO:

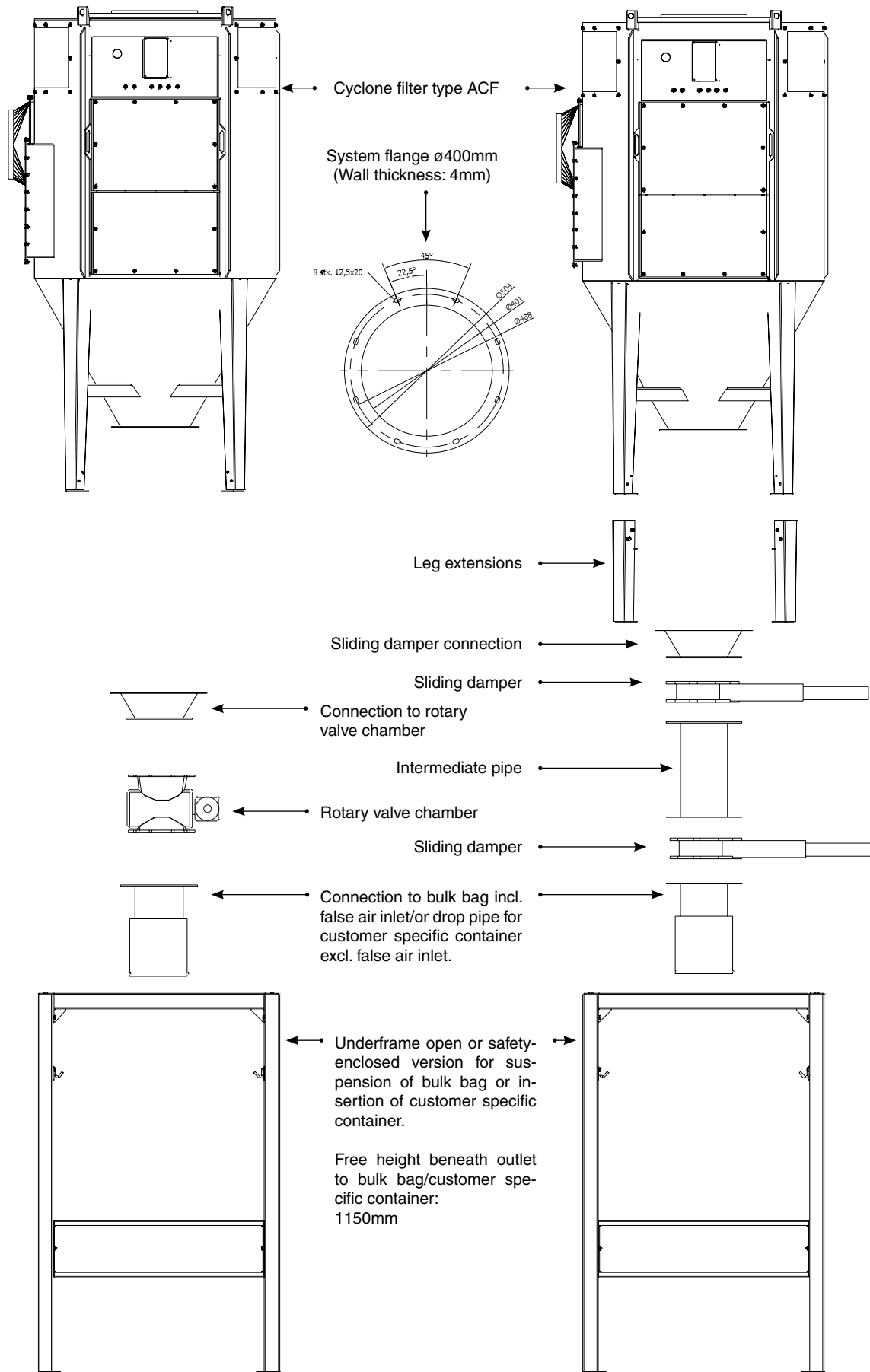

We refer to the Gram price list for the complete program!

Cyclone filter type ACF-A / -T-A / -V-A / -T-V-A / -A-HO / -T-A-HO is available in the sizes as stated in the forms below.

Please, contact us for assistance in selecting the optimal unit taking into consideration air volume, dust type and volume, operation times etc.

- **ACF-A / ACF-V-A / ACF-A-HO** has as standard side mounted inlet and outlet
- **ACF-T-A / ACF-T-V-A / ACF-T-A-HO** has side mounted inlet and outlet in top (prepared for built-on fan)
- **ACF-V-A / ACF-T-V-A** is for high vacuum application
- **ACF-A-HO / ACF-T-A-HO** is prepared for mounting of Hörbiger-valve (delivered excl. mounting flange and valve that have to be ordered separately)

Cyclone filter type ACF-A (max. 5,000Pa):
ATEX-zone: 20/22 / 20/21

Type	ATEX zone 20/22 Order no.	ATEX zone 20/21 Order no.	ΔP start/end ³⁾ [Pa]	Number filter cartridge	Number jet valve	G113 filter area [m ²]	Compressed-air [L/min.]	Number dust container (stand.) [L]	Number dust container (option ⁴⁾) [L]	Weight [kg]
ACF-A 39 ⁵⁾	10 420 010	10 420 020	200/2000	3 ¹⁾	3	39	30	1x72	1x150	290
ACF-A 52 ⁵⁾	10 420 060	10 420 070	200/2000	4 ¹⁾	4	52	30	1x72	1x150	360
ACF-A 52 H ⁵⁾	10 420 11002	10 420 120	200/2000	2 ²⁾	2	52	30	1x72	1x150	270
ACF-A 78 H	10 420 210	10 420 220	200/2000	3 ²⁾	3	78	30	1x72	1x150	350
ACF-A 104 H	10 420 310	10 420 320	200/2000	4 ²⁾	4	104	30	1x72	1x150	420
ACF-A 130 H	10 420 410	10 420 420	200/2000	5 ²⁾	5	130	30	1x72	1x150	500
ACF-A 182 H	10 420 460	10 420 470	200/2000	7 ²⁾	7	182	30	1x72	1x150	650
ACF-A 234 H	10 420 510	10 420 520	200/2000	9 ²⁾	9	234	30	1x72	1x150	740
ACF-A 260 DH	10 420 710	10 420 720	200/2000	10 ²⁾	10	260	60	2x72	2x150	990
ACF-A 364 DH	10 420 760	10 420 770	200/2000	14 ²⁾	14	364	60	2x72	2x150	1290
ACF-A 468 DH	10 420 810	10 420 820	200/2000	18 ²⁾	18	468	60	2x72	2x150	1470

Cyclon filter type ACF-T-A (max. 5,000Pa):
ATEX-zone: 20/22 / 20/21

Type	ATEX zone 20/22 Order no.	ATEX zone 20/21 Order no.	ΔP start/end ³⁾ [Pa]	Number filter cartridge	Number jet valve	G113 filter area [m ²]	Compressed-air [L/min.]	Number dust container (stand.) [L]	Number dust container (option ⁴⁾) [L]	Weight [kg]
ACF-T-A 39 ⁵⁾	10 420 050	10 421 050	200/2000	3 ¹⁾	3	39	30	1x72	1x150	290
ACF-T-A 52 ⁵⁾	10 420 100	10 421 100	200/2000	4 ¹⁾	4	52	30	1x72	1x150	360
ACF-T-A 52 H ⁵⁾	10 420 150	10 421 150	200/2000	2 ²⁾	2	52	30	1x72	1x150	270
ACF-T-A 78 H	10 420 250	10 421 250	200/2000	3 ²⁾	3	78	30	1x72	1x150	350
ACF-T-A 104 H	10 420 350	10 421 350	200/2000	4 ²⁾	4	104	30	1x72	1x150	420
ACF-T-A 130 H	10 420 455	10 421 455	200/2000	5 ²⁾	5	130	30	1x72	1x150	500
ACF-T-A 182 H	10 420 500	10 421 500	200/2000	7 ²⁾	7	182	30	1x72	1x150	650
ACF-T-A 234 H	10 420 550	10 421 550	200/2000	9 ²⁾	9	234	30	1x72	1x150	740
ACF-T-A 260 DH	10 420 750	10 421 750	200/2000	10 ²⁾	10	260	60	2x72	2x150	990
ACF-T-A 364 DH	10 420 800	10 421 800	200/2000	14 ²⁾	14	364	60	2x72	2x150	1290
ACF-T-A 468 DH	10 420 850	10 421 850	200/2000	18 ²⁾	18	468	60	2x72	2x150	1470

¹⁾ Filter cartridge $\phi 325 \times 660\text{mm}/\phi 13.5\text{mm}$, 13m², G113 (08 128 900)

²⁾ Filter cartridge $\phi 325 \times 1320\text{mm}/\phi 13.5\text{mm}$, 26m², G113 (08 129 400)

³⁾ Pressure drop stated over filter cartridge

⁴⁾ Please, note that unit height is increased by 330mm.

⁵⁾ Unit delivered without bar grating/with wind deflector

**Cyclone filter type ACF-V-A (max. 40,000Pa):
ATEX-zone: 20/22 / 20/21**

Type	ATEX zone 20/22 Order no.	ATEX zone 20/21 Order no.	Δ P start/end ³⁾ [Pa]	Number filter cartridge	Number jet valve	G113 filter area [m ²]	Compressed-air [L/min.]	Number dust container (stand.) [L]	Number dust container (option ³⁾) [L]	Weight [kg]
ACF-V-A 52 H ⁴⁾	10 420 130	10 420 140	200/2000	2 ¹⁾	2	52	30	1x67	1x145	340
ACF-V-A 78 H	10 420 230	10 420 240	200/2000	3 ¹⁾	3	78	30	1x67	1x145	340
ACF-V-A 104 H	10 420 330	10 420 340	200/2000	4 ¹⁾	4	104	30	1x67	1x145	420
ACF-V-A 130 H	10 420 480	10 420 440	200/2000	5 ¹⁾	5	130	30	1x67	1x145	500

**Cyclone filter type ACF-T-V-A (max. 40,000Pa):
ATEX-zone: 20/22 / 20/21**

Type	ATEX zone 20/22 Order no.	ATEX zone 20/21 Order no.	Δ P start/end ³⁾ [Pa]	Number filter cartridge	Number jet valve	G113 filter area [m ²]	Compressed-air [L/min.]	Number dust container (stand.) [L]	Number dust container (option ³⁾) [L]	Weight [kg]
ACF-T-V-A 52 H ⁴⁾	10 420 145	10 421 145	200/2000	2 ¹⁾	2	52	30	1x67	1x145	340
ACF-T-V-A 78 H	10 420 245	10 421 245	200/2000	3 ¹⁾	3	78	30	1x67	1x145	340
ACF-T-V-A 104 H	10 420 345	10 421 345	200/2000	4 ¹⁾	4	104	30	1x67	1x145	420
ACF-T-V-A 130 H	10 420 450	10 421 450	200/2000	5 ¹⁾	5	130	30	1x67	1x145	500

¹⁾ Filter cartridge $\varnothing 325 \times 1320\text{mm}/\varnothing 13.5\text{mm}$, 26m², G113 (08 129 400)

²⁾ Pressure drop stated over filter cartridge

³⁾ Please, note that unit height is increased by 330mm.

⁴⁾ Unit delivered without bar grating/with wind deflector

Replacement membrane:

Type	Relief membrane +0.2 bar [mm]	Numer Relief membrane Max. 5,000Pa [pc.]	Numer Relief membrane Max. 50,000Pa [pc.]	Placement Relief membrane on
ACF-A / ACF-T39	653 x 653	1	1	Inlet
ACF-A / ACF-T 52	653 x 653	1	1	Inlet
ACF-A / ACF-T / ACF-V / ACF-T-V-A 52 H	653 x 653	1	1	Inlet
ACF-A / ACF-T / ACF-V / ACF-T-V-A 78 H	653 x 653	1	1	Inlet
ACF-A / ACF-T / ACF-V / ACF-T-V-A 104 H	653 x 653	1	1	Inlet
ACF-A / ACF-T / ACF-V / ACF-T-V-A 130 H	720 x 1020	1	1 ⁵⁾	Inlet
ACF-A / ACF-T-A 182 H	720 x 1020	1	1 ⁵⁾	Inlet
ACF-A / ACF-T-A 234 H	720 x 1020	1	1 ⁵⁾	Inlet
ACF-A / ACF-T-A 260 DH	2 x (720 x 1020)	2	2 ⁵⁾	Front at inlet
ACF-A / ACF-T 364 DH	2 x (720 x 1020)	2	2 ⁵⁾	Front at inlet
ACF-A / ACF-T 468 DH	2 x (720 x 1020)	2	2 ⁵⁾	Front at inlet

For further information see price list group 10

⁵⁾ Only 30,000Pa

Cyclone filter type ACF-A-HO (max. 5,000Pa):**ATEX-zone: 20/22 / 20/21****Note: Unit type is prepared for mounting of Hörbiger-valve (requires mounting flange and valve)**

Type	ATEX zone 20/22 Order no.	ATEX zone 20/21 Order no.	Δ P start/end ³⁾ [Pa]	Number filter cartridge	Number jet valve	G113 filter area [m ²]	Compressed-air [L/min.]	Number dust container (stand.) [L]	Number dust container (option ⁴⁾) [L]	Weight ⁶⁾ [kg]
ACF-A-HO 39 ⁵⁾	10 422 010	10 422 020	200/2000	3 ¹⁾	3	39	30	1x72	1x150	332
ACF-A-HO 52 ⁵⁾	10 422 060	10 422 070	200/2000	4 ¹⁾	4	52	30	1x72	1x150	352
ACF-A-HO 52 H ⁵⁾	10 422 110	10 422 120	200/2000	2 ²⁾	2	52	30	1x72	1x150	308
ACF-A-HO 78 H	10 422 210	10 422 220	200/2000	3 ²⁾	3	78	30	1x72	1x150	400
ACF-A-HO 104 H	10 422 310	10 422 320	200/2000	4 ²⁾	4	104	30	1x72	1x150	474
ACF-A-HO 130 H	10 422 410	10 422 420	200/2000	5 ²⁾	5	130	30	1x72	1x150	561
ACF-A-HO 182 H	10 422 460	10 422 470	200/2000	7 ²⁾	7	182	30	1x72	1x150	746
ACF-A-HO 234 H	10 422 510	10 422 520	200/2000	9 ²⁾	9	234	30	1x72	1x150	859

Cyclone filter type ACF-T-A-HO (max. 5,000Pa):**ATEX-zone: 20/22 / 20/21****Note: Unit type is prepared for mounting of Hörbiger-valve (requires mounting flange and valve)**

Type	ATEX zone 20/22 Order no.	ATEX zone 20/21 Order no.	Δ P start/end ³⁾ [Pa]	Number filter cartridge	Number jet valve	G113 filter area [m ²]	Compressed-air [L/min.]	Number dust container (stand.) [L]	Number dust container (option ⁴⁾) [L]	Weight ⁶⁾ [kg]
ACF-T-A-HO 39 ⁵⁾	10 423 050	10 423 060	200/2000	3 ¹⁾	3	39	30	1x72	1x150	323
ACF-T-A-HO 52 ⁵⁾	10 423 100	10 423 110	200/2000	4 ¹⁾	4	52	30	1x72	1x150	356
ACF-T-A-HO 52 H ⁵⁾	10 423 150	10 423 160	200/2000	2 ²⁾	2	52	30	1x72	1x150	312
ACF-T-A-HO 78 H	10 423 250	10 423 260	200/2000	3 ²⁾	3	78	30	1x72	1x150	406
ACF-T-A-HO 104 H	10 423 350	10 423 360	200/2000	4 ²⁾	4	104	30	1x72	1x150	474
ACF-T-A-HO 130 H	10 423 455	10 423 465	200/2000	5 ²⁾	5	130	30	1x72	1x150	541
ACF-T-A-HO 182 H	10 423 500	10 423 510	200/2000	7 ²⁾	7	182	30	1x72	1x150	722
ACF-T-A-HO 234 H	10 423 550	10 423 560	200/2000	9 ²⁾	9	234	30	1x72	1x150	936

¹⁾ Filter cartridge $\varnothing 325 \times 660\text{mm}/\varnothing 13.5\text{mm}$, 13m², G113 (08 128 900)²⁾ Filter cartridge $\varnothing 325 \times 1320\text{mm}/\varnothing 13.5\text{mm}$, 26m², G113 (08 129 400)³⁾ Pressure drop stated over filter cartridge⁴⁾ Please, note that unit height is increased by 330mm.⁵⁾ Unit delivered without bar grating/with wind deflector⁶⁾ Stated excl. flange and valve.**Mounting flanges and Hörbiger-valves for cyclone filter type ACF-A-HO / ACF-T-A-HO:**

Mounting flange for	Order no.
Hörbiger-valve 266 EVN 2.0	10 223 010
Hörbiger-valve 320 EVN 2.0	10 223 060
Hörbiger-valve 420 EVN 2.0	10 223 110
Hörbiger-valve 480 EVN 2.0	10 223 210
Hörbiger-valve 565 EVN 2.0	10 223 310
Hörbiger-valve 645 EVN 2.0	10 223 410
Hörbiger-valve 735 EVN 2.0	10 223 460

Hörbiger-valve	Order no.
Hörbiger-valve 266 EVN 2.0	10 224 010
Hörbiger-valve 320 EVN 2.0	10 224 060
Hörbiger-valve 420 EVN 2.0	10 224 110
Hörbiger-valve 480 EVN 2.0	10 224 210
Hörbiger-valve 565 EVN 2.0	10 224 310
Hörbiger-valve 645 EVN 2.0	10 224 410
Hörbiger-valve 735 EVN 2.0	10 224 460